

REELSTRONG®

UTILITY FLEET

PL12 POWERLOCK™ STRINGING REEL TRAILER SPECS



EXCLUSIVE STANDARD ADDED VALUE:

- POWERLOCK™ Technology Provides Industry Leading Safety, Ease of Use, Low Maintenance and Durability.
 - SAFETY and Peace of Mind
 - No Pins, Cotters, or Lanyards that Secure the Reel Arbor (which is the most critical safety point).
 - Faster Reel Loading, Unloading, and Deployment Reduces Labor Costs and Fatigue on Workers.

BUILT FOR SAFETY. BUILT FOR SPEED. BUILT TO LAST.

CAPACITIES

- PL12: 22,100 lbs. GVWR @ 15% Tongue Weight
- PL12-C: 22,100 lbs. GVWR @ 15% Tongue Weight

AXLES

- PL12: Tandem 10K lbs. Sprung
- PL12-C: Tandem 10K lbs. Sprung

WHEELS

- PL12: (4) 17.5 x 6.75 HC / 8 on 6.5 BC w/ 0.19 Inset
- PL12-C: (4) 17.5 x 6.75 HC / 8 on 6.5 BC w/ 0.19 Inset

TIRES

- PL12: (4) ST-215/75R17.5 LR-H Tires
- PL12-C: (4) ST-215/75R17.5 LR-H Tires

BRAKES

- PL12: 12.25" x 3.38" Electric w/ Safety Breakaway Kit
- PL12-C: 12.25" x 3.38" Electric w/ Safety Breakaway Kit

PAYLOAD: ALL FINAL PAYLOADS BASED ON CHOSEN MODEL AND OPTIONS

REEL WEIGHT (PAYLOAD)

- PL12: 12,000 lbs. Approx.
- PL12-C: 12,000 lbs. Approx.

REEL DIAMETER: 108" Maximum

REEL WIDTH: 60" Maximum

REEL SHAFT DIAMETER: 3.00" Tube w/ Heavy Duty Lifting Lug Centering Collar

OVERALL LENGTH: 198.75" Approx.

OVERALL WIDTH: 102"

OVERALL WEIGHT:

- PL12: 3,300 lbs. Approx.
- PL12-C: 3,900 lbs. Approx.

Actual Trailer Weight will Vary with Options & Finishes Chosen.

STANDARD FEATURES

- POWERLOCK™ Technology Provides Industry Leading Safety, Ease of Use, Low Maintenance and Durability.
- Oil Bath Hubs (Greaseable Option All)
- Electric Brakes
- Wheel Chock Holders

STANDARD TRAILER BODY

- Heavy Duty 6" X 4" X ¼" Frame
- 6-Position Adjustable Hitch
- ½" X 42" GR70 Yellow Zinc Safety Chains with Hooks
- 12,000 lbs. Static Front Jack w/ Spring Return
- Ground Lug: Copper Alloy Bolted to Frame
- Fenders: ⅛" Tread Plate
- (2) Rear 12,000 lbs. Static Stabilizer Jacks w/ Spring Return

WIRING

- DOT / ICC Approved LED Lights and Conspicuity Reflective Tape
- FMVSS / CMVSS Standard 108 LED Lighting
- Sealed Beam, Rubber Mounted Stop, Turn, Tail and Marker Lights
- 100% Sealed Heat-Shrunked Wiring Connections w/ Full Loom
- Breakaway Kit with Absorbed Glass Mat (AGM) Battery

PAINT

- Biodegradable Pretreat Acid Cleaning
(Superior to re-used sandblasting material that can impregnate metals with oil)
- Seams Caulked
- Rust Preventative 2-Part Epoxy Primer
- Standard Colors: Red, Black, White and CAT Yellow

OPTIONS

- 13 HP HONDA Engine Hydraulic Power Pack Comes STANDARD w/ ENGINE COVER, 15 Gallon Reservoir, Replaceable Oil Filter, Pressure Gauge and Solar Fade Resistant Plastic Control Placard. (Electric Start Optional)
- 10-Year Galvanized Structural Warranty (2-Year Painted)
- 3,300 ft/lbs Hydraulic Take-up Retriever
- 2-7/16" Universal Adapter for Capstan and Power Reel Attachments
- 7 Inch General Purpose Capstan
- Collapsible Power Reel
- Rotating Arbor Ground
- Rewind Leveler
- 20" Bronze Alloy Ventilated Reel Brake

OPTIONS (cont.)

- 16" Long 6-Bolt Hitch Extension (w/ 52" Safety Chains and Breakaway Cable Extension)
- 3" Lunette Eye
- 10K-HD / 15K / 20K Axles Available w/ Air Brakes
- Anti-Lock Brakes (ABS)
- Aluminum or Steel Toolbox
- Wiring Connections Soldered and Sealed w/ Heat Shrink Tubing
- Plug-and-Play Sealco Wiring Harness
- Wheel Chocks: Rubber or All Weather Galvanized Grip Strut
- Spare Tire and Mount
- Solar Charged Breakaway Kit
- Strobe Warning Lights
- All Stainless Steel Fasteners (1/2" and under)
- Hydraulic Front Jack
- Truck-Lite Lighting
- Lug Nut Indicators

1 2 3 4 5 6 7 8

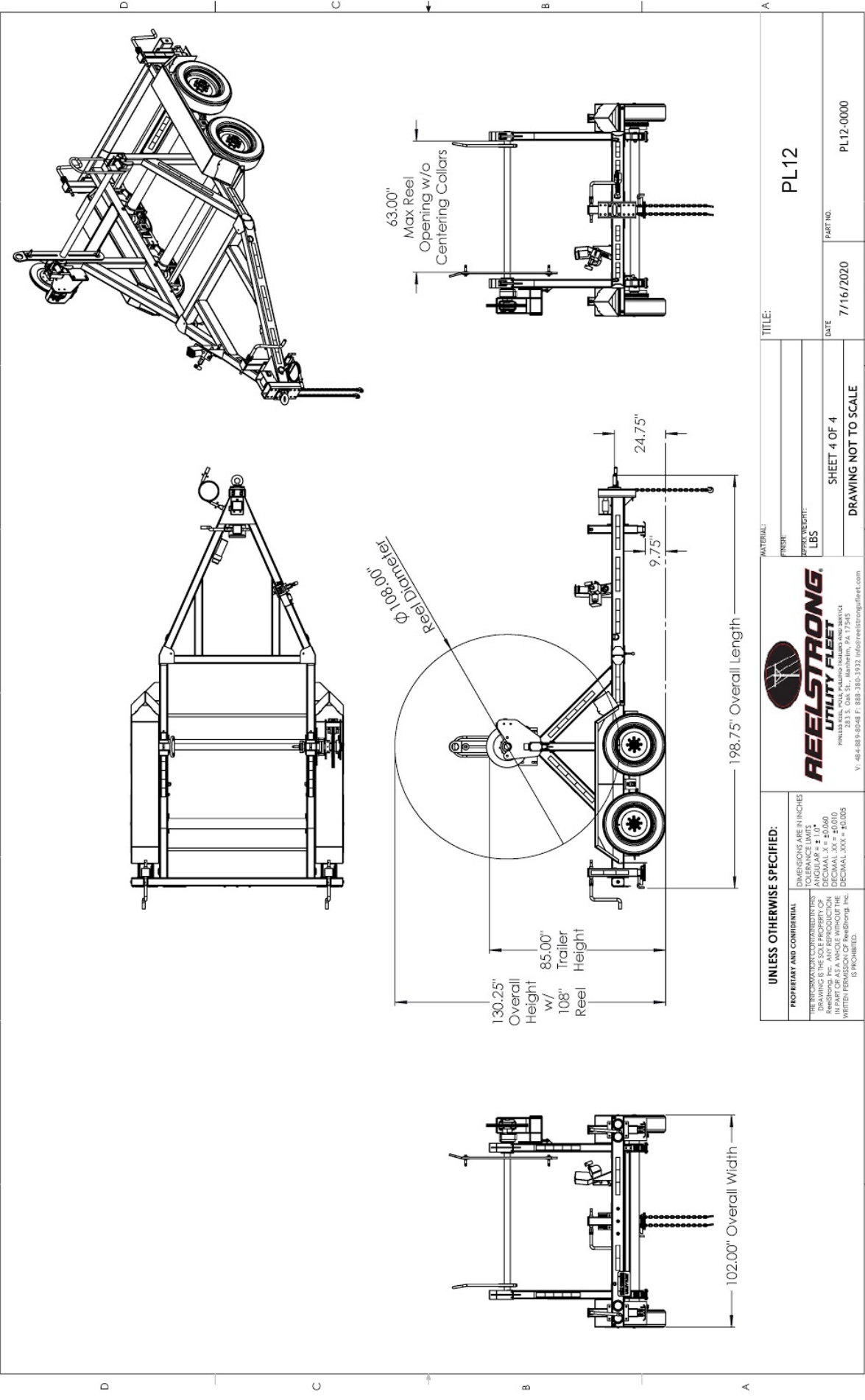

UNLESS OTHERWISE SPECIFIED: <small>PROPRIETARY AND CONFIDENTIAL</small> INFORMATION CONTAINED HEREIN IS THE SOLE PROPERTY OF REELSTRONG UTILITY FLEET. NO PART OF THIS DRAWING IS TO BE REPRODUCED OR TRANSMITTED IN ANY FORM OR BY ANY MEANS, ELECTRONIC OR MECHANICAL, INCLUDING PHOTOCOPYING, RECORDING, OR BY ANY INFORMATION STORAGE AND RETRIEVAL SYSTEM, WITHOUT THE WRITTEN PERMISSION OF ReelStrong, Inc. IS PROHIBITED.		REELSTRONG UTILITY FLEET <small>283 S. Oak St., Warminster, PA 17245 V: 484-889-8048 F: 888-380-3932 info@reelstrongfleet.com</small>	
UNLESS OTHERWISE SPECIFIED: <small>DIMENSIONS ARE IN INCHES</small> TOLERANCE LIMITS: DECIMAL .125" = ±0.005 DECIMAL .125" = ±0.010 DECIMAL .125" = ±0.010 DECIMAL .125" = ±0.005		PL12 TITLE:	
MATERIAL: FINISH: WEIGHT: LBS		DATE: 7/16/2020 PART NO.: PL12-0000	
SHEET 4 OF 4 DRAWING NOT TO SCALE			

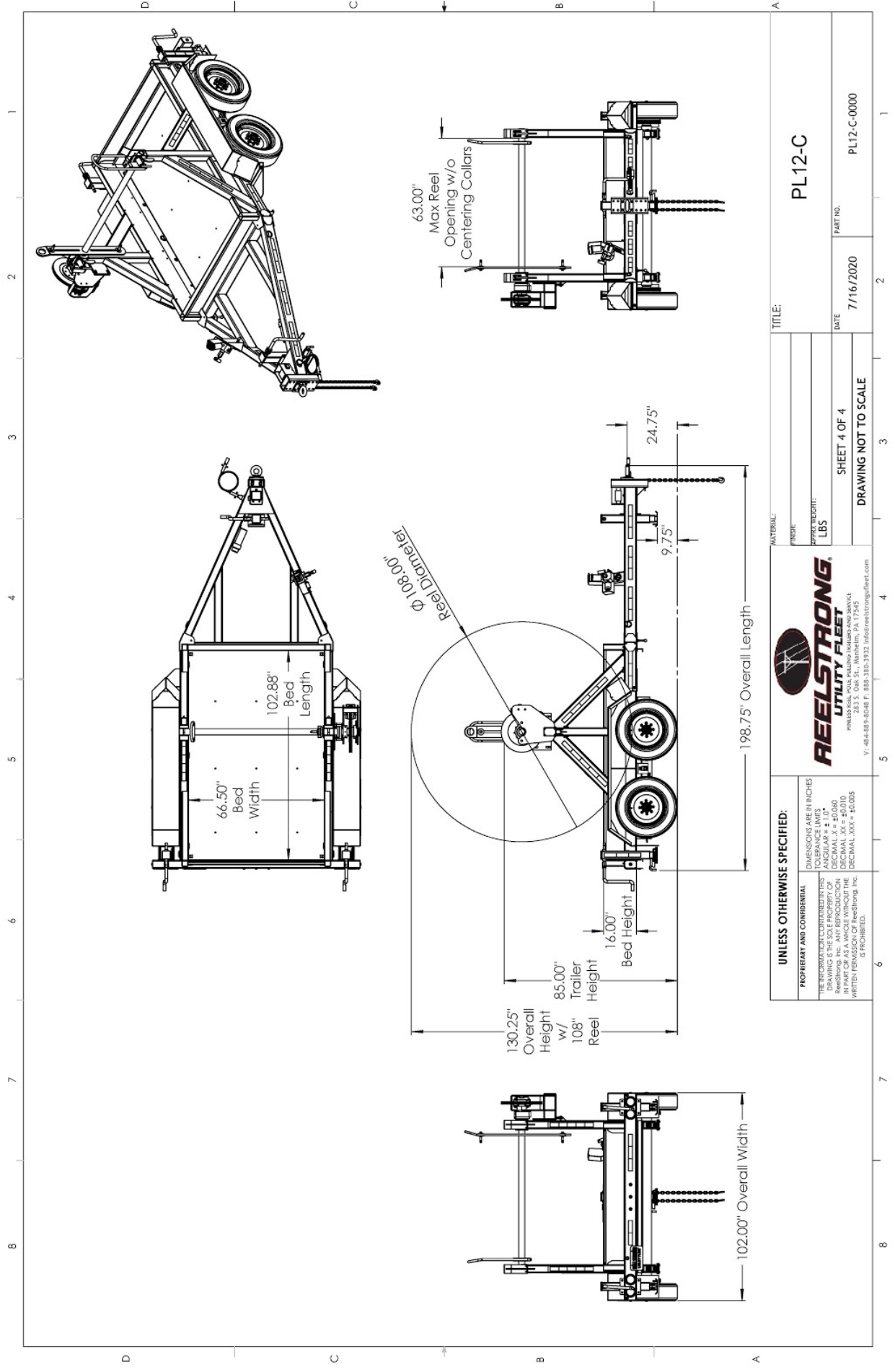

UNLESS OTHERWISE SPECIFIED:		REELSTRONG UTILITY FLEET <small>PH155 STEEL, POLY, PULVERIZED RUBBER SERVICE V1-484-889-8048 F-888-3910-3932 info@reelstrongfleet.com</small>	
PROPRIETARY AND CONFIDENTIAL THE INFORMATION CONTAINED HEREIN IS THE SOLE PROPERTY OF REELSTRONG, INC. ANY REPRODUCTION OR TRANSMISSION OF THIS DRAWING WITHOUT THE WRITTEN PERMISSION OF REELSTRONG, INC. IS PROHIBITED.		DIMENSIONS ARE IN INCHES TOLERANCE LIMITS ANGULAR ± 1.0° DECIMAL .XX ± .010 DECIMAL .XXX ± .005	
TITLE:		PL12-C	
MATERIAL:		LBS	
FINISH:		DATE: 7/16/2020	
APPROVED BY:		PART NO. PL12-C-0000	
DRAWING NOT TO SCALE			

8 7 6 5 4 3 2 1

D C B A