

REELSTRONG®

UTILITY FLEET

PL8 POWERLOCK™ STRINGING REEL TRAILER SPECS



EXCLUSIVE STANDARD ADDED VALUE:

- POWERLOCK™ Technology Provides Industry Leading Safety, Ease of Use, Low Maintenance and Durability.
 - SAFETY and Peace of Mind
 - No Pins, Cotters, or Lanyards that Secure the Reel Arbor (which is the most critical safety point).
 - Faster Reel Loading, Unloading, and Deployment Reduces Labor Costs and Fatigue on Workers.

BUILT FOR SAFETY. BUILT FOR SPEED. BUILT TO LAST.

CAPACITIES

- PL8: 10,900 lbs. GVWR @ 13.5% Tongue Weight

AXLES

- PL8: 10K lbs. Sprung

WHEELS

- PL8: (2) 17.5 x 6.75 HC / 8 on 6.5 BC w/ 0.19 Inset

TIRES

- PL8: (2) ST-215/75R17.5 LR-H Tires

BRAKES

- PL8: 12.25" x 3.38" Electric w/ Safety Breakaway Kit

PAYLOAD: ALL FINAL PAYLOADS BASED ON CHOSEN MODEL AND OPTIONS

REEL WEIGHT (PAYLOAD)

- PL8: 8,000 lbs. Approx.

REEL DIAMETER: 96" Maximum

REEL WIDTH: 60" Maximum

REEL SHAFT DIAMETER: 2.50" Tube w/ Centering Collars

OVERALL LENGTH: 125" Approx.

OVERALL WIDTH: 96" Approx.

OVERALL WEIGHT: 1,800 lbs. Approx. (Actual Trailer Weight will Vary with Options & Finishes Chosen)

STANDARD FEATURES

- POWERLOCK™ Technology Provides Industry Leading Safety, Ease of Use, Low Maintenance and Durability.
- Oil Bath Hubs (Greaseable Option All)
- Electric Brakes
- Wheel Chock Holders

STANDARD TRAILER BODY

- Heavy Duty 5" X 2" X ¼" Frame
- 6-Position Adjustable Hitch

—All specifications / designs are subject to change without notice - All GVWR and reel capacities are de-rateable to your needs.

STANDARD TRAILER BODY (cont.)

- 3/8" X 36" GR70 Yellow Zinc Safety Chains with Hooks
- 8,000 lbs. Static Front Jack
- Ground Lug: Copper Alloy Bolted to Frame
- Fenders: 1/8" Plate
- (2) Rear 8,000 lbs. Static Stabilizer Jacks

WIRING

- DOT / ICC Approved LED Lights and Conspicuity Reflective Tape
- FMVSS / CMVSS Standard 108 LED Lighting
- Sealed Beam, Rubber Mounted Stop, Turn, Tail and Marker Lights
- 100% Sealed Heat-Shrunked Wiring Connections w/ Full Loom
- Breakaway Kit with Absorbed Glass Mat (AGM) Battery

PAINT

- Biodegradable Pretreat Acid Cleaning
(Superior to re-used sandblasting material that can impregnate metals with oil)
- Seams Caulked
- Rust Preventative 2-Part Epoxy Primer
- Standard Colors: Red, Black, White and CAT Yellow

OPTIONS

- 13 HP HONDA Engine Hydraulic Power Pack Comes STANDARD w/ ENGINE COVER, 15 Gallon Reservoir, Replaceable Oil Filter, Pressure Gauge and Solar Fade Resistant Plastic Control Placard. (Electric Start Optional)
- 10-Year Galvanized Structural Warranty (2-Year Painted)
- 3,300 ft/lbs Hydraulic Take-up Retriever (Shown with Capstan & Adapter)
- 2-7/16" Universal Adapter for Capstan and Power Reel Attachments
- 7 Inch General Purpose Capstan
- Collapsible Power Reel
- Rotating Arbor Ground
- Rewind Leveler
- 16" Bronze Alloy Ventilated Reel Brake w/ Ventilated Guard
- 16" Long 6-Bolt Hitch Extension (w/ 52" Safety Chains and Breakaway Cable Extension)
- 3" Lunette Eye
- Aluminum or Steel Toolbox
- 10K-HD / 15K / 20K Axles Available w/ Air Brakes
- Anti-Lock Brakes (ABS)
- Wiring Connections Soldered and Sealed w/ Heat Shrink Tubing
- Plug-and-Play Sealco Wiring Harness
- Wheel Chocks: Rubber or All Weather Galvanized Grip Strut

OPTIONS (cont.)

- Spare Tire and Mount
- Solar Charged Breakaway Kit
- Strobe Warning Lights
- All Stainless Steel Fasteners (½" and under)
- Hydraulic Front Jack
- Truck-Lite Lighting
- Lug Nut Indicators

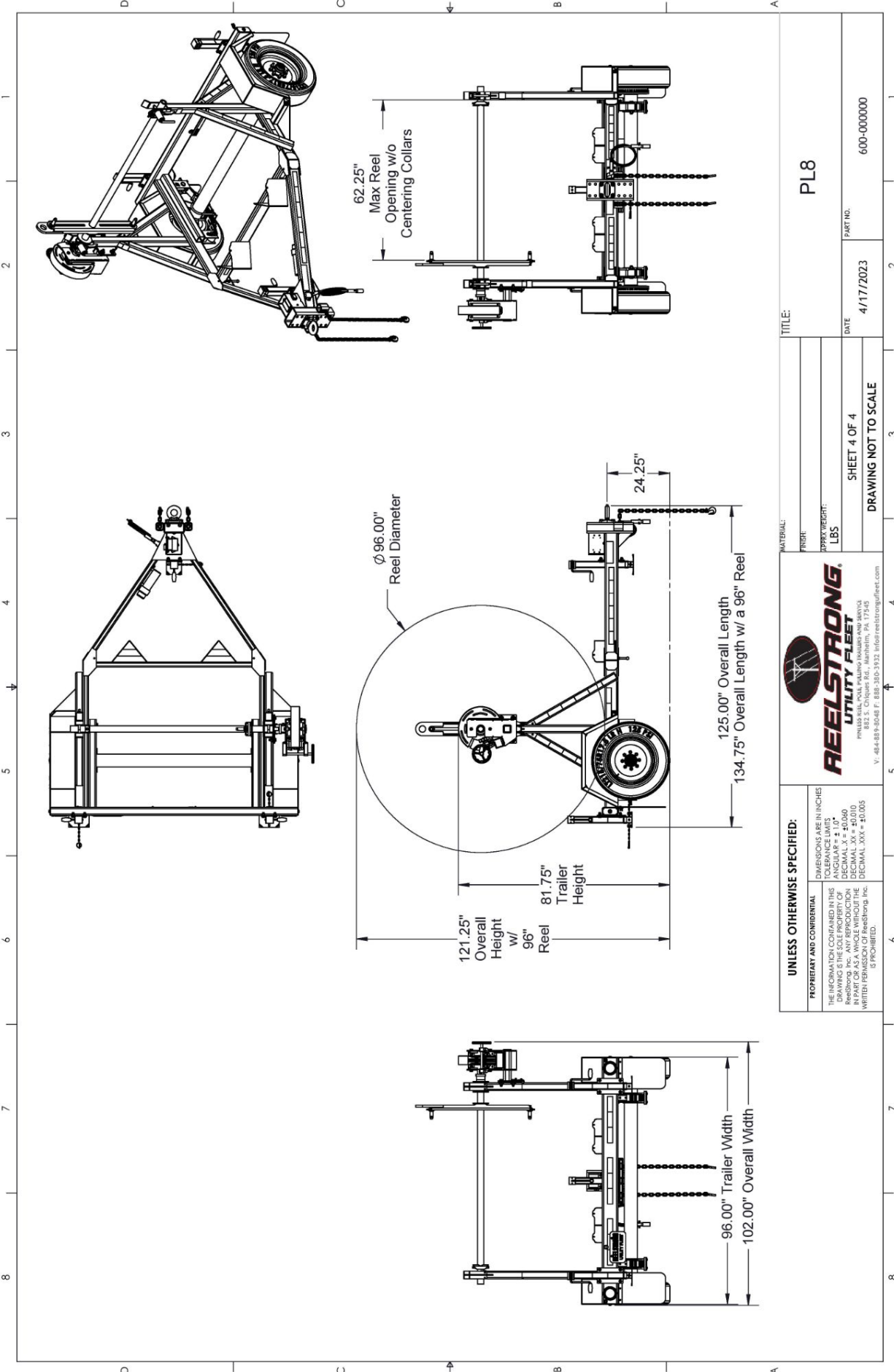

TITLE: PL8	
DATE: 4/17/2023	PART NO.: 600-000000

MATERIAL:	
FINISH:	
APPROX WEIGHT:	LBS
SHEET 4 OF 4	
DRAWING NOT TO SCALE	

REELSTRONG
 UTILITY FLEET
PROUDLY MFG. IN THE USA
 V. 484-889-3048 F. 888-350-3932 info.reelstrongfleet.com

UNLESS OTHERWISE SPECIFIED:

DIMENSIONS ARE IN INCHES
 TOLERANCE LIMITS:
 ANGULAR ± 1.0°
 DECIMAL ± 0.005
 DECIMAL .XX ± 0.010
 DECIMAL .XXX ± 0.005
 ALL DIMENSIONS ARE UNLESS OTHERWISE SPECIFIED
 WRITTEN PERMISSION OF ReelStrong, Inc.
 IS PROHIBITED.

THE INFORMATION CONTAINED IN THIS DRAWING IS THE SOLE PROPERTY OF ReelStrong, Inc. ANY REPRODUCTION, DISTRIBUTION, OR DISSEMINATION OF THIS DRAWING WITHOUT THE WRITTEN PERMISSION OF ReelStrong, Inc. IS PROHIBITED.