

REELSTRONG®

UTILITY FLEET

SL50-45 SLIDELOCK™ REEL TRAILER SPECS

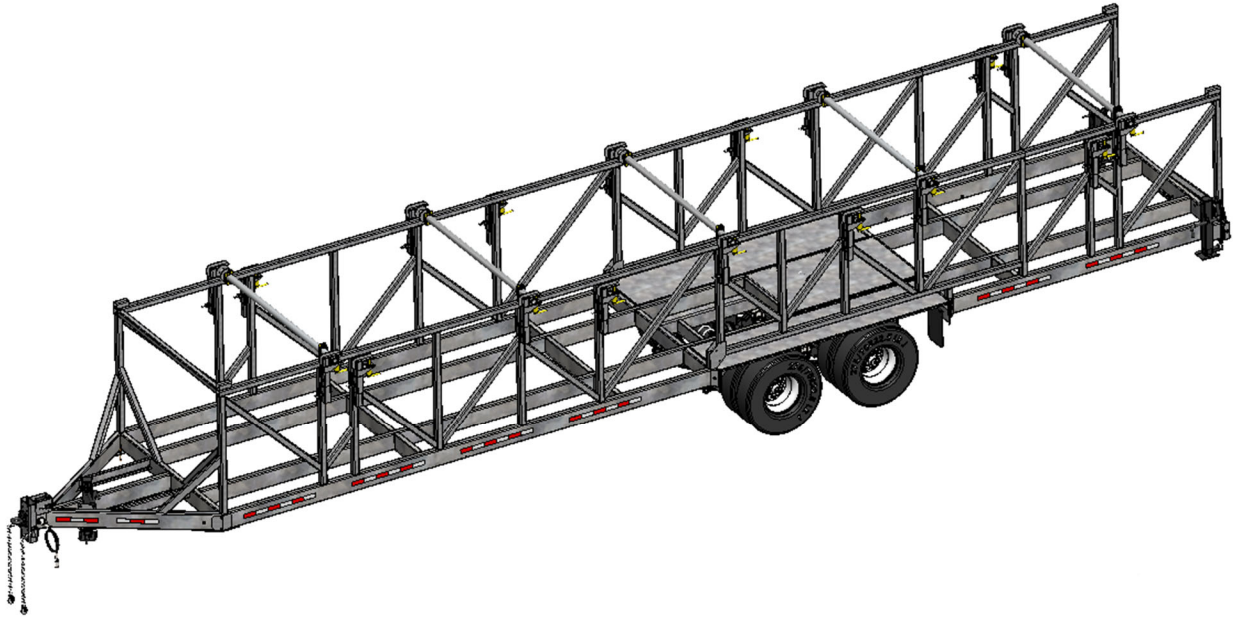

EXCLUSIVE STANDARD ADDED VALUE:

- SLIDELOCK™ Technology Provides Industry Leading Safety, Ease of Use, Low Maintenance and Durability.
 - SAFETY and Peace of Mind
 - No Pins, Cotters, or Lanyards that Secure the Reel Arbor (which is the most critical safety point).
 - Faster Reel Loading, Unloading, and Deployment Reduces Labor Costs and Fatigue on Workers.

BUILT FOR SAFETY. BUILT FOR SPEED. BUILT TO LAST.

CAPACITIES: 57,500 lbs. GVWR @ 15% Tongue Weight

AXLES: Tandem 25K lbs. Sprung

WHEELS: (8) 22.5 x 9HC, 10 on 285.75mm BC, 7.00 Outset Wheel

TIRES: (8) 295/60R22.5 LR-J Tires

BRAKES: 12.25" x 7.50" **AIR BRAKES REQUIRED**

PAYLOAD: ALL FINAL PAYLOADS BASED ON CHOSEN MODEL AND OPTIONS

REEL CAPACITY:

(4x) 120" Diameter x 77" Width x 11,000 lbs.

or

(5x) 96" Diameter x 77" Width x 8,800 lbs.

REEL SHAFT DIAMETER: 3.00" Tube w/ Centering Collars

OVERALL LENGTH: 48'

OVERALL WIDTH: 101.50"

OVERALL WEIGHT: 13,400 lbs. Approx.

(Actual Trailer Weight will Vary with Options & Finishes Chosen)

STANDARD FEATURES

- SLIDELOCK Technology Provides Industry Leading Safety, Ease of Use, Low Maintenance and Durability.
- Oil Bath Hubs (Greaseable Option All)
- Electric Brakes
- Wheel Chock Holders

STANDARD TRAILER BODY

- Heavy Duty 8" X 3" X ¼"
- 6-Position Adjustable Hitch
- ½" X 36" GR70 Yellow Zinc Safety Chains with Hooks
- 12,000 lbs. Static Front Jack w/ Spring Return
- Ground Lug: Copper Alloy Bolted to Frame
- Fenders: ⅛" Tread Plate
- A-frame: Approx. 6' Long

WIRING

- DOT / ICC Approved LED Lights and Conspicuity Reflective Tape
- FMVSS / CMVSS Standard 108 LED Lighting

WIRING (cont.)

- Sealed Beam, Rubber Mounted Stop, Turn, Tail and Marker Lights
- 100% Sealed Heat-Shrunked Wiring Connections w/ Full Loom
- Breakaway Kit with Absorbed Glass Mat (AGM) Battery

PAINT

- Biodegradable Pretreat Acid Cleaning (Superior to re-used sandblasting material that can impregnate metals with oil)
- Seams Caulked
- Rust Preventative 2-Part Epoxy Primer
- Standard Colors: Red, Black, White and CAT Yellow

OPTIONS

- 10-Year Galvanized Structural Warranty (2-Year Painted)
- 16" Long 6-Bolt Hitch Extension (w/ 52" Safety Chains and Breakaway Cable Extension)
- Aluminum or Steel Toolbox
- Wiring Connections Soldered and Sealed w/ Heat Shrink Tubing
- Plug-and-Play Sealco Wiring Harness
- Wheel Chocks: Rubber or All Weather Galvanized Grip Strut
- Spare Tire and Mount
- Solar Charged Breakaway Kit
- Strobe Warning Lights
- All Stainless Steel Fasteners (1/2" and under)
- Truck-Lite Lighting
- Lug Nut Indicators

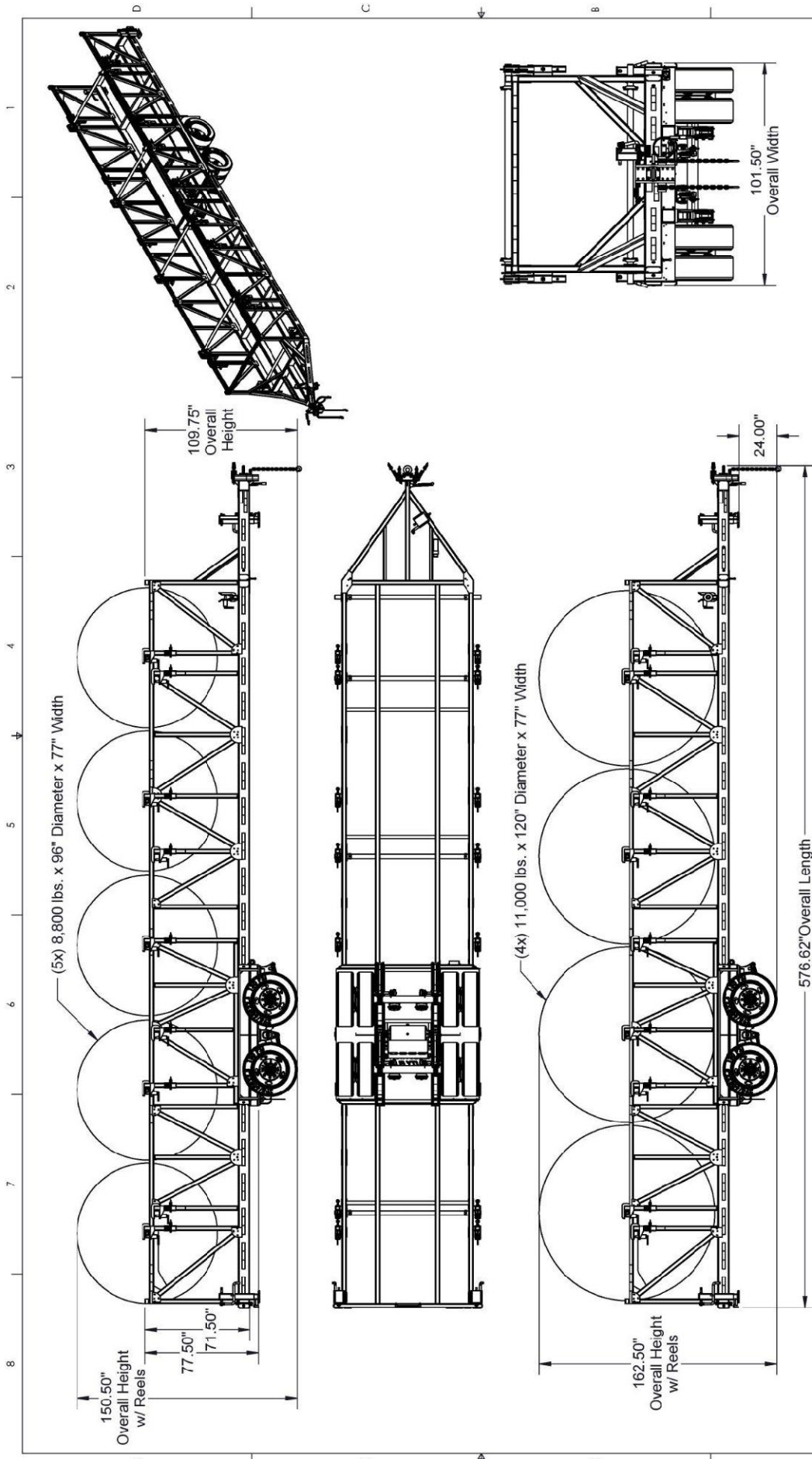

NOTE: LARGE REELS MAY EXCEED 13' 6" ROAD HEIGHT LIMITS		REELSTRONG UTILITY FLEET PROFESSIONAL, POLAR, PALMBO, HONOLULU AND SERVICE 882 S. Cluques Rd., Manalapan, PA, 17243 P: 717-618-8320 F: 888-380-3932, info@reelstrongfleet.com	TITLE: SL50-45
UNLESS OTHERWISE SPECIFIED: <small> DIMENSIONS ARE IN INCHES TOLERANCE LIMITS DECIMAL .XX = ±0.010 DECIMAL .XXX = ±0.005 FRACTIONS ARE IN INCHES TOLERANCE LIMITS DECIMAL .XX = ±0.010 DECIMAL .XXX = ±0.005 WRITTEN PERMISSION OF Reelstrong, Inc. IS PROHIBITED. </small>	MATERIAL: LBS FINISH: LBS APPROX WEIGHT: LBS		DATE: 3/14/2024 PART NO.: 550-000000
SHEET 4 OF 4 DRAWING NOT TO SCALE			