

REELSTRONG®

UTILITY FLEET

CP3 COIL PIPE TRAILER SPECS



EXCLUSIVE STANDARD ADDED VALUE:

- Industry Leading Safety, Ease of Use, Low Maintenance and Durability.
- Floating Spindle Turret Allows for Adjustability from 28" ID to 83" ID
- Turntable Holds Coils with a Height up to 48"
- **LIFETIME WARRANTY** Max-Roller™ System for Enhanced Stability and Smoother Operation
- Brake Easily Engages by Pulling a Hand Lever
- Low Center of Gravity
- Great Price

BUILT FOR SAFETY. BUILT FOR SPEED. BUILT TO LAST.

CAPACITIES: 3,000 lbs. GVWR

AXLES: 3K lbs. Torsion

WHEELS: (2) 15 x 6JJ / 5 on 4.5 BC w/ Zeraset

TIRES: (2) ST-205/75R15 LR-C Tires

BRAKES: No Brakes

PAYLOAD: ALL FINAL PAYLOADS BASED ON CHOSEN MODEL AND OPTIONS

COIL WEIGHT (PAYLOAD): 1,400 lbs. Approx.

COIL HEIGHT (from turntable): 48”

COIL DIAMETER: Fabricated ID Spokes with “Floating” Spindle 28”-83” ID Adjustability

OVERALL LENGTH: 154.50” Approx.

OVERALL WIDTH: 96” Approx.

CURB WEIGHT: 1,600 lbs.

Approx. Actual Trailer Weight will Vary with Options & Finishes Chosen.

STANDARD FEATURES

- Industry Leading Safety, Ease of Use, Low Maintenance and Durability.
- Oil Bath Hubs (Greaseable Option)
- Wheel Chock Holders
- (4) Removable 2” x 2” Vertical Outside Diameter Posts
- Floating Spindle Turret Allows for Adjustability from 28” ID to 83”
- Turntable Holds Coils with a Height up to 48”
- Brake Easily Engages by Pulling a Hand Lever
- **LIFETIME WARRANTY** Max-Roller™ System for Enhanced Stability and Smoother Operation
- 2.50” Lunette Eye
- 8,000 lbs. Static Front Jack

STANDARD TRAILER BODY

- Heavy Duty 5” Channel Frame
- 5-Position Adjustable Hitch
- 3/8” X 36” GR70 Yellow Zinc Safety Chains with Hooks
- Fenders: 1/8” Plate

—All specifications / designs are subject to change without notice - All GVWR and reel capacities are de-rateable to your needs.

WIRING

- DOT / ICC Approved LED Lights and Conspicuity Reflective Tape
- FMVSS / CMVSS Standard 108 LED Lighting
- Sealed Beam, Rubber Mounted Stop, Turn, Tail and Marker Lights
- 100% Sealed Heat-Shrunked Wiring Connections w/ Full Loom
- Breakaway Kit with Absorbed Glass Mat (AGM) Battery

PAINT

- Biodegradable Pretreat Acid Cleaning
(Superior to re-used sandblasting material that can impregnate metals with oil)
- Seams Caulked
- Rust Preventative 2-Part Epoxy Primer
- Standard Colors: Red, Black, White and CAT Yellow

OPTIONS

- 10-Year Galvanized Structural Warranty (2-Year Painted)
- Aluminum or Steel Toolbox
- Wiring Connections Soldered and Sealed w/ Heat Shrink Tubing
- Plug-and-Play Sealco Wiring Harness
- Wheel Chocks: Rubber or All Weather Galvanized Grip Strut
- Spare Tire and Mount
- All Stainless Steel Fasteners (1/2" and under)
- Line Tamer / Pipe Straightener w/ Radial Articulating Arm
- Tracer Wire Holder Kit
 - (2) Bolt-on Front Mounts
 - (2) Bolt-on Rear Mounts
 - (1) Positive Locking Tracer Wire Holder Assembly
 - Wire Holder can be Moved to any of the Four Positions for easy Pay-Out
 - Wire Holder is Positive Locking to Prevent Movement During Transportation.
- Truck-Lite Lighting
- Lug Nut Indicators

1 2 3 4 5 6 7 8

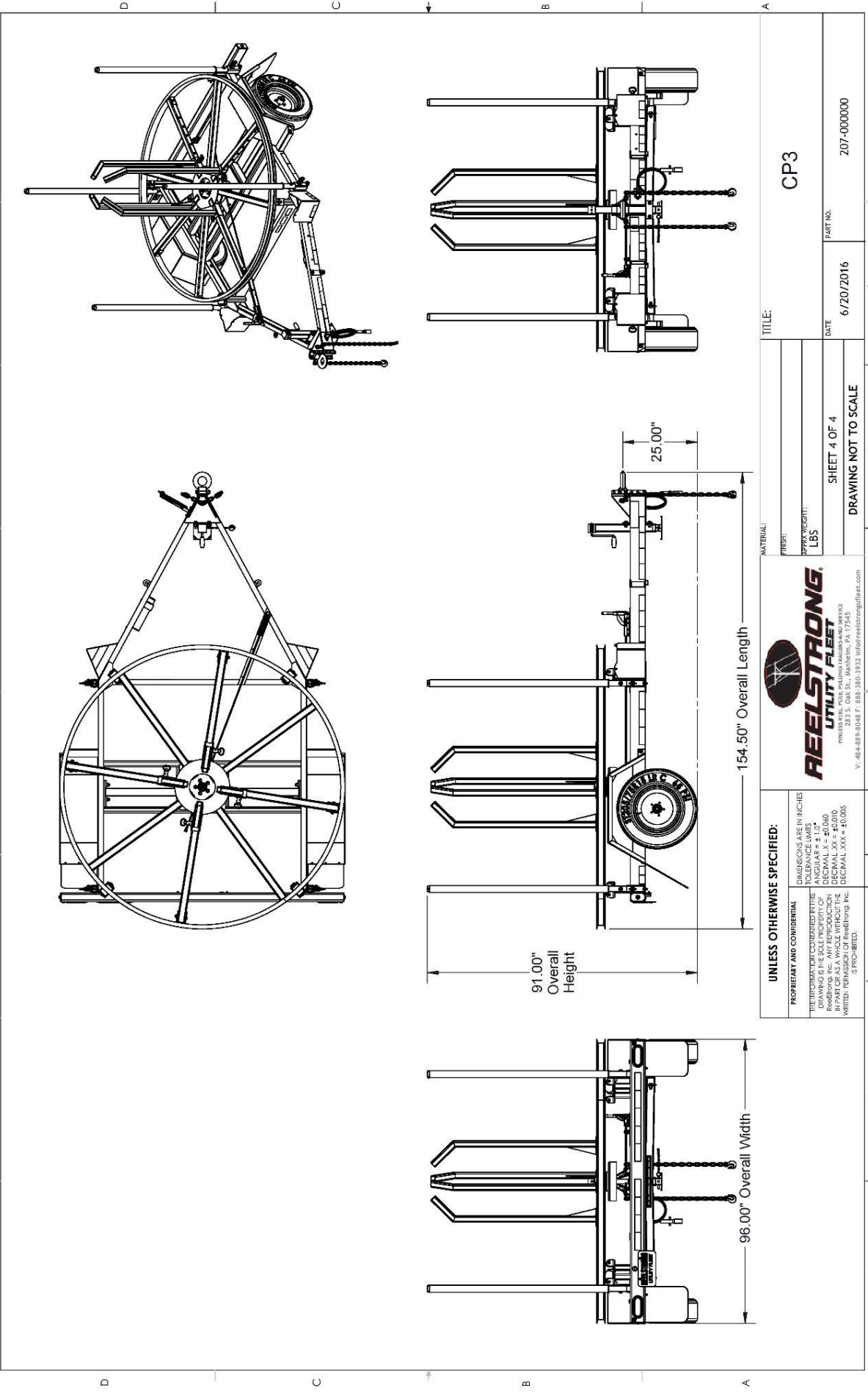

UNLESS OTHERWISE SPECIFIED: DIMENSIONS ARE IN INCHES TOLERANCE LIMITS: ANGULAR ± 1.0° LINEAR ± 0.010 DECIMAL XX ± 0.010 DECIMAL XXX ± 0.005 UNLESS NOTED OTHERWISE WRITTEN PERMISSION OF ReelStrong, Inc. IS PROHIBITED.		REELSTRONG UTILITY FLEET <small>UTILITY FLEET, PULLEY HOLDERS AND SERVICE V. 484-889-8048 F. 888-350-3932 info@reelstrongfleet.com</small>	
MATERIAL: _____ FINISH: _____ APPROX WEIGHT: LBS		TITLE: CP3	
SHEET 4 OF 4 DRAWING NOT TO SCALE		DATE: 6/20/2016	PART NO.: 207-000000