

REELSTRONG®

UTILITY FLEET

PTFRE LIFETIME WARRANTY MEGA-ROLLER™ w/ SELF-SECURING SECURELOCK™ FRONT & REEL EXTENDING POLE TRAILER SPECS

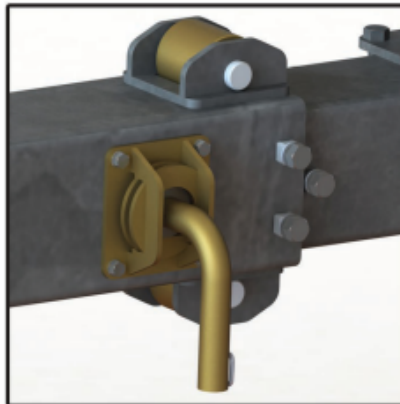

EXCLUSIVE STANDARD ADDED VALUE:

- SECURELOCK™ Technology Provides Industry Leading Safety, Ease of Use, Low Maintenance and Durability.
- MEGA-ROLLER™ Tongue Extension Mechanism with Self-Lubricating Super Oilite Bearings Provides a Smooth “ONE MAN OPERATION” of the Extendable Tongue Unit. NO TRUCK NEEDED to Extend or Retract Tongue!
- ADJUSTABLE Front Pole Seat, Featuring EZ Slide Stanchions. No More Rusted / Seized Lever Lock Stanchions.

BUILT FOR SAFETY. BUILT FOR SPEED. BUILT TO LAST.

CAPACITIES

- PTFRE20: 22,100 lbs. GVWR @ 15% Tongue Weight

AXLES

- PTFRE20: Tandem 10K lbs. Sprung

WHEELS

- PTFRE20: (4) 17.50 x 6.75 HC / 8 on 6.5 BC w/ 0.19 Inset

TIRES

- PTFRE20: (4) ST-215/75R17 LR-H Tires

BRAKES

- PTFRE20: 12.25" x 3.38" Electric w/ Safety Breakaway Kit

PAYLOAD: ALL FINAL PAYLOADS BASED ON CHOSEN MODEL AND OPTIONS

OVERALL LENGTH Retracted / Extended Lengths:

- PTFRE20: Eight Positions: 30'-53'
- **Optional** Additional / Less Extension Increments Available

OVERALL WIDTH: 96"

OVERALL WEIGHT: *Actual Trailer Weight will Vary with Options & Finishes Chosen.*

POLE SEAT HEIGHT: 37"

CARGO BED

- PTFRE20: 90" X 48" (Customizable)

STANDARD FEATURES

- **LIFETIME WARRANTY** MEGA-ROLLER EXTEND / RETRACT SYSTEM
(NO WEAR PADS TO REPLACE!)
- **SECURELOCK™** Tongue Lock Roller System
- NO-BIND EZ-SLIDE STANCHIONS
- Oil Bath Hubs (Greaseable Option All)
- Electric Brakes
- Adjustable Spring Pads
- Slipper Springs
- Reinforced Spring Hangers
- Wheel Chock Holders
- Front and Rear Extension for Optimal Tongue Weight Control

POLE SECUREMENT

- Pole Rests: 5" H Beam (Level Lock Stanchions Optional)
- Front Pole Rests: 5" H Beam (Lever Lock Stanchions Optional)
- Winch Binders, Ratcheting Breaker Bar and Bar Pocket

STANDARD TRAILER BODY

- Heavy Duty 6" X 6" X 1/4" Wall Male Extendable Tongue
- Heavy Duty 8" X 8" X 1/4" Wall Female Structural Tube
- Base Frame: 8" Fish Plated C-Channel
- Oversized Precision Rollers w/ Bronze Bearings
- 7-Position Adjustable Hitch
- 3/8" X 36" GR70 Yellow Zinc Safety Chains with Hooks
- Removable Male Male Extension Tongue
- Standard Cargo Area
- 12,000 lbs. Static Front Jack w/ Spring Return

FRONT POLE SEAT OPTIONS (Mounted on Male Tongue)

- 48" Wide 5" H-Beam Pole Seat w/ EZ-Slide Stanchions (Standard)
- 60" Wide 5" H-Beam Pole Seat w/ EZ-Slide Stanchions (Optional)
- 96" Wide 5" H-Beam Pole Seat w/ EZ-Slide Stanchions (Optional)

WIRING

- DOT / ICC Approved LED Lights and Conspicuity Reflective Tape
- Internal Cat Track Protects Wiring (and air brakes if applicable)
- Removable Rear Access Door for Cat Track and Wiring
- Sealed Beam, Rubber Mounted Stop, Turn, Tail and Marker Lights
- 100% Sealed Heat-Shrunked Wiring Connections w/ Full Loom
- Breakaway Kit with Absorbed Glass Mat (AGM) Battery

PAINT

- Biodegradable Pretreat Acid Cleaning
(Superior to re-used sandblasting material that can impregnate metals with oil)
- Seams Caulked
- Rust Preventative 2-Part Epoxy Primer
- Standard Colors: Red, Black, White and CAT Yellow

OPTIONS

- 10-Year Galvanized Structural Warranty (2-Year Painted)
- 10K-HD / 15K / 20K Axles Available w/ Air Brakes
- Anti-Lock Brakes (ABS)
- 16" Long 6-Bolt Hitch Extension (w/ 52" Safety Chains and Breakaway Cable Extension)
- 3" Lunette Eye

OPTIONS (cont.)

- Lever Lock Stanchions
- Wiring Connections Soldered and Sealed w/ Heat Shrink Tubing
- Plug-and-Play Sealco Wiring Harness
- Jack Handle Extension for Full Width (96") Pole Seat
- Wheel Chocks: Rubber or All Weather Galvanized Grip Strut
- Spare Tire and Mount
- 6D-Rings Front, Center and Rear for Cargo / Transformers
- Front Removable / Adjustable Pole Seat Mounted on Front Male Tongue
(Not Recommended)
- Extension Configurations: Customizable
(additional / less extension increments available)
- Solar Charged Breakaway Kit
- Truck-Lite Lighting
- Lug Nut Indicators

OPTIONAL LIGHT BAR

- All TIG Welded Aluminum
- Contains (4) Four 4" Stop/Turn / Tail Rubber Mounted Sealed Beam LED Lights
- (3) Three Center ID Marker Lights
- (2) Two Side Marker Lights
- 4-Way Die Cast Connector
- 35' Standard Electric Cable Length with a 4-Way Connector Plug